

PARAMETRIC SOLIDS

Objective:

The objective of this tutorial is to demonstrate the procedure for generating a parametric solid object. The tutorial will illustrate the generation of a parametric solid through both direct generation and derivative actions. The approach to making a solid geometric primitive varies according the software application, but most applications allow you to create a solid entity by selecting an object from a list of primitives or through generative actions like extrude and revolve.

Direct Generation of a Parametric Solid Entity:

Inputs:

There are no entity inputs, just coordinates and parameters. Depending upon the type of entity, you will be required to input coordinate triplets (x,y,z) and the parameters that contribute to the definition of the object. You can respond to the request for inputs by either typing with the keyboard or snapping to points within the graphics window. The chart below outlines the typical inputs required for the creation of parametric solids.

Overview:

Parametric solid entities are defined through the selection of an entity from a menu or interface and directly generating the object through the input of parameters.

Solid Entity Type	Typical Inputs	Variation
Box	Corner to Corner and Height	Center, Height, Length
Sphere	Center Point, (Radius or Diameter)	
Cylinder	Center Point (Radius or Diameter) and Height	
Cone	Center Point (Radius or Diameter) and Height	
Wedge	Corner, Length, Width and Height	
Torus	Center Point, Tube Radius, Torus Radius	Center point Tube Radius, Torus Diameter

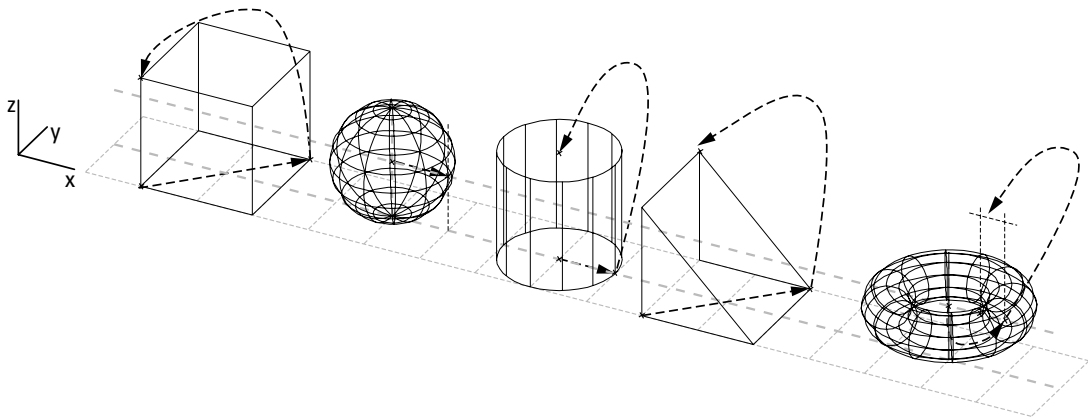

Derivative Actions: SWEEP

Inputs:

Closed polylines or polygons.

Overview:

Solid objects generated through derivative actions require you to act upon two-dimensional entities. In order to define the solid volume an input entity and the path of extrusion is required. The path of extrusion can be either implicit or explicit. A path is implicit when invoking the extrude command because the entity is being swept perpendicular to the construction plane. An explicit condition is when a geometrical entity (line, polyline, spline) is used to define the path of the sweep operation. In most situations the input entities can be transformed through tapering while performing the command.

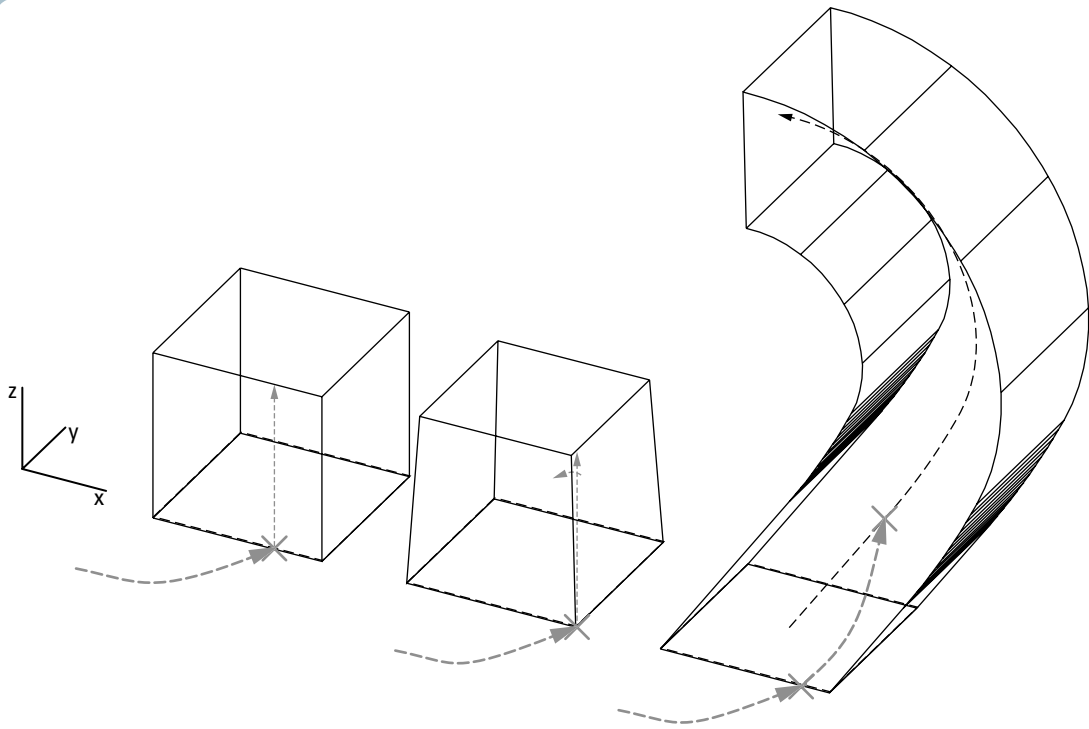

Process:

Simple Extrusion

1. Invoke the extrude command.
2. Select the entity to be extruded.
3. Specify the height.

Process:

Extrude & Taper

1. Invoke the extrude command.
2. Select the entity to be extruded.
3. Specify the height.
4. Specify the angle of taper.

Process:

Extrude Along Path

1. Invoke the extrude command.
2. Select the entity to be extruded.
3. Select the path that will be used for the extrusion.

Derivative Actions: REVOLVE

Overview:

When revolving a two-dimensional entity in order to create a solid object you must determine the axis of rotation and the degree of revolution.

Inputs:

Spline, line, or polyline . Entities to be revolved should be closed.

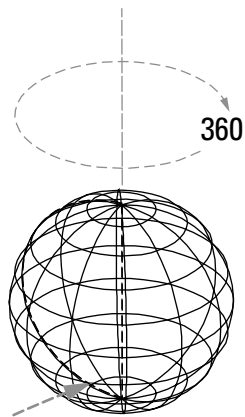
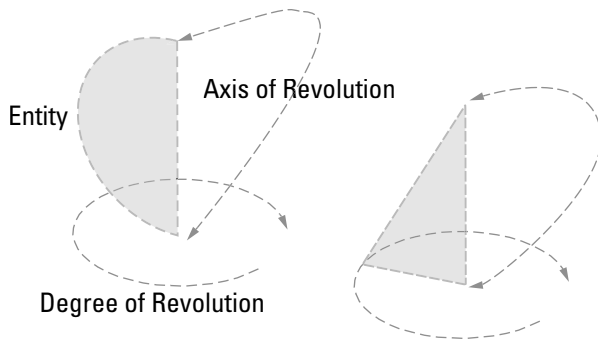

Sphere

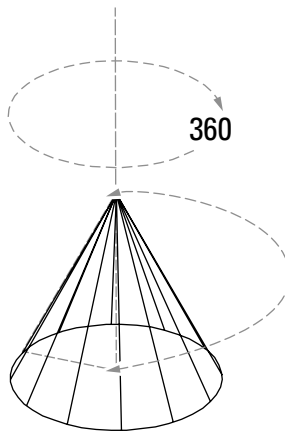

Cone

Process:

1. Invoke the Revolve Command.
2. Specify the axis of revolution.
3. Select the entity to be revolved.
4. Specify the degree of revolution.